

Features

- Capacity - 1,000 Kg - 5,000 Kg
- Red LED Display with 5 digits and display size of 30mm
- Aluminum Die Cast Housing with Satin finish
- Integrated Load cell and measuring circuit.
- Standard bow shackle dimension.
- Standard eye hook dimension.
- Infrared remote control.
- Rechargeable battery.

Functions

- Zero.
- Tare.
- Hold.
- Battery Supervision.
- Overload Alarm/Record.
- Digital Calibration.
- 3-point Calibration.
- Unit Switch.
- Resolution Switch.

Specification

| | |
|--------------------|-------------|
| Max. Capacity (T) | 1T, 3T, 5T |
| Min. Capacity (Kg) | 100Kg |
| Division (Kg) | 5Kg |
| Net Weight | 31Kg |
| Accuracy Class | OIML III |
| Tare Range | 100%F.S. |
| Zero Range | 4%F.S. |
| Safe Overload | 120%F.S. |
| Ultimate Overload | 400%F.S. |
| Overload Alarm | 100%F.S.+9e |
| Battery | 6V/4Ah |
| Adaptor | DC7.2V |
| Battery life | >80h |
| Temperature range | -10°C~40°C |

Electronic Dynamometer



Dimensions:

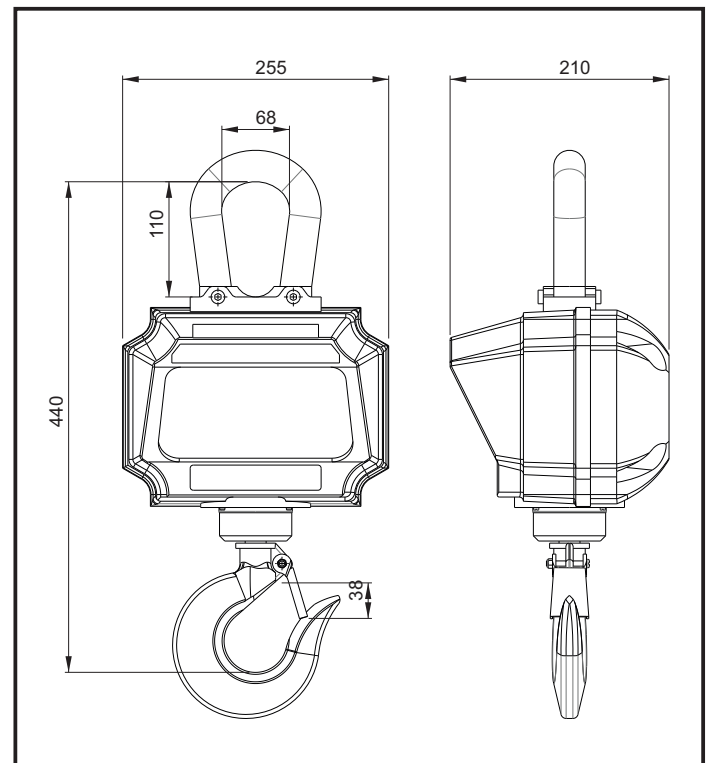

Speed-O-Controls Pvt. Ltd.

H. O. Unit - I : C-15/16, Nand Jyot Industrial Estate, Andheri-Kurla Road, Mumbai - 400072 ,
Tel : (022) 42469700-30
Fax : (022) 42469797
E-mail : sales@socgroup.in

Unit - II: Plot No. 4912, G. I. D. C., Phase IV, Vatva, Ahmedabad - 382445
Tel.: (079) 40083201/2/3/4,
Fax : (079) 25841056,
E-mail : sales.amd@socgroup.in

Visit us at :
www.speedocontrols.com
www.socremote.com

